

SkyLine Pro LPG Gas Combi Oven 10GN1/1

ITEM # _____

MODEL # _____

NAME # _____

SIS # _____

AIA # _____

217962 (ECOG101C2H0)

SkyLine Pro Combi Boilerless Oven with digital control, 10x1/1GN, gas, programmable, automatic cleaning, LPG

Short Form Specification

Item No.

- Combi oven with digital interface with guided selection.
- Boilerless steaming function to add and retain moisture.
 - OptiFlow air distribution system to achieve maximum performance with 5 fan speed levels.
 - SkyClean: Automatic and built-in self cleaning system. 5 automatic cycles (soft, medium, strong, extra strong, rinse-only).
 - Cooking modes: Programs (a maximum of 100 recipes can be stored); Manual; EcoDelta cooking cycle.
 - Automatic backup mode to avoid downtime.
 - USB port to download HACCP data, programs and settings. Connectivity ready.
 - Single sensor core temperature probe.
 - Double-glass door with LED lights.
 - Stainless steel construction throughout.
 - Supplied with n.1 tray rack 1/1 GN, 67 mm pitch.

Main Features

- Digital interface with LED backlight buttons with guided selection.
- Boilerless steaming function to add and retain moisture for high quality, consistent cooking results.
- Dry hot convection cycle (max 300 °C) ideal for low humidity cooking. Automatic moistener (11 settings) for boiler-less steam generation.
- EcoDelta cooking: cooking with food probe maintaining preset temperature difference between the core of the food and the cooking chamber.
- Programs mode: a maximum of 100 recipes can be stored in the oven's memory, to recreate the exact same recipe at any time. 4-step cooking programs also available.
- Fan with 5 speed levels from 300 to 1500 RPM and reverse rotation for optimal evenness. Fan stops in less than 5 seconds when door is opened.
- Single sensor core temperature probe included.
- Automatic fast cool down and pre-heat function.
- SkyClean: Automatic and built-in self cleaning system. 5 automatic cycles (soft, medium, strong, extra strong, rinse-only).
- Different chemical options available: solid (phosphate-free), liquid (requires optional accessory).
- GreaseOut: predisposed for integrated grease drain and collection for safer operation (dedicated base as optional accessory).
- USB port to download HACCP data, share cooking programs and configurations. USB port also allows to plug-in sous-vide probe (optional accessory).
- Connectivity ready for real time access to connected appliances from remote and HACCP monitoring (requires optional accessory).
- Back-up mode with self-diagnosis is automatically activated if a failure occurs to avoid downtime.
- Capacity: 10 GN 1/1 trays.
- Connectivity ready for real time access to connected appliances from remote and data monitoring (requires optional accessory - contact the Company for more details).
- OptiFlow air distribution system to achieve maximum performance in chilling/heating evenness and temperature control thanks to a special design of the chamber.

Construction

- Double thermo-glazed door with open frame construction, for cool outside door panel. Swing hinged easy-release inner glass on door for easy cleaning.
- Seamless hygienic internal chamber with all rounded corners for easy cleaning.
- 304 AISI stainless steel construction throughout.
- Front access to control board for easy service.
- IPX 5 spray water protection certification for easy cleaning.
- Supplied with n.1 tray rack 1/1 GN, 67 mm pitch.

Sustainability



APPROVAL: _____

- Human centered design with 4-star certification for ergonomics and usability.
- Wing-shaped handle with ergonomic design and hands-free opening with the elbow, making managing trays simpler. Protected by registered design (EM003143551 and related family).

Optional Accessories

- | | | | | | |
|---|------------|--------------------------|--|------------|--------------------------|
| • Water softener with cartridge and flow meter (high steam usage) | PNC 920003 | <input type="checkbox"/> | • Tray rack with wheels, 8 GN 1/1, 80mm pitch | PNC 922602 | <input type="checkbox"/> |
| • Water filter with cartridge and flow meter for 6 & 10 GN 1/1 ovens (low-medium steam usage - less than 2hrs per day full steam) | PNC 920004 | <input type="checkbox"/> | • Bakery/pastry tray rack with wheels holding 400x600mm grids for 10 GN 1/1 oven and blast chiller freezer, 80mm pitch (8 runners) | PNC 922608 | <input type="checkbox"/> |
| • Water softener with salt for ovens with automatic regeneration of resin | PNC 921305 | <input type="checkbox"/> | • Slide-in rack with handle for 6 & 10 GN 1/1 oven | PNC 922610 | <input type="checkbox"/> |
| • Wheel kit for 6 & 10 GN 1/1 and 2/1 GN oven base (not for the disassembled one) | PNC 922003 | <input type="checkbox"/> | • Open base with tray support for 6 & 10 GN 1/1 oven | PNC 922612 | <input type="checkbox"/> |
| • Pair of AISI 304 stainless steel grids, GN 1/1 | PNC 922017 | <input type="checkbox"/> | • Cupboard base with tray support for 6 & 10 GN 1/1 oven | PNC 922614 | <input type="checkbox"/> |
| • Pair of grids for whole chicken (8 per grid - 1,2kg each), GN 1/1 | PNC 922036 | <input type="checkbox"/> | • Hot cupboard base with tray support for 6 & 10 GN 1/1 oven holding GN 1/1 or 400x600mm trays | PNC 922615 | <input type="checkbox"/> |
| • AISI 304 stainless steel grid, GN 1/1 | PNC 922062 | <input type="checkbox"/> | • External connection kit for liquid detergent and rinse aid | PNC 922618 | <input type="checkbox"/> |
| • Grid for whole chicken (4 per grid - 1,2kg each), GN 1/2 | PNC 922086 | <input type="checkbox"/> | • Grease collection kit for GN 1/1-2/1 cupboard base (trolley with 2 tanks, open/close device for drain) | PNC 922619 | <input type="checkbox"/> |
| • External side spray unit (needs to be mounted outside and includes support to be mounted on the oven) | PNC 922171 | <input type="checkbox"/> | • Stacking kit for 6 GN 1/1 oven placed on gas 10 GN 1/1 oven | PNC 922623 | <input type="checkbox"/> |
| • Baking tray for 5 baguettes in perforated aluminum with silicon coating, 400x600x38mm | PNC 922189 | <input type="checkbox"/> | • Trolley for slide-in rack for 6 & 10 GN 1/1 oven and blast chiller freezer | PNC 922626 | <input type="checkbox"/> |
| • Baking tray with 4 edges in perforated aluminum, 400x600x20mm | PNC 922190 | <input type="checkbox"/> | • Trolley for mobile rack for 6 GN 1/1 on 6 or 10 GN 1/1 ovens | PNC 922630 | <input type="checkbox"/> |
| • Baking tray with 4 edges in aluminum, 400x600x20mm | PNC 922191 | <input type="checkbox"/> | • Stainless steel drain kit for 6 & 10 GN oven, dia=50mm | PNC 922636 | <input type="checkbox"/> |
| • Pair of frying baskets | PNC 922239 | <input type="checkbox"/> | • Plastic drain kit for 6 & 10 GN oven, dia=50mm | PNC 922637 | <input type="checkbox"/> |
| • AISI 304 stainless steel bakery/pastry grid 400x600mm | PNC 922264 | <input type="checkbox"/> | • Grease collection kit for GN 1/1-2/1 open base (2 tanks, open/close device for drain) | PNC 922639 | <input type="checkbox"/> |
| • Double-step door opening kit | PNC 922265 | <input type="checkbox"/> | • Wall support for 10 GN 1/1 oven | PNC 922645 | <input type="checkbox"/> |
| • Grid for whole chicken (8 per grid - 1,2kg each), GN 1/1 | PNC 922266 | <input type="checkbox"/> | • Banquet rack with wheels holding 30 plates for 10 GN 1/1 oven and blast chiller freezer, 65mm pitch | PNC 922648 | <input type="checkbox"/> |
| • Grease collection tray, GN 1/1, H=100 mm | PNC 922321 | <input type="checkbox"/> | • Banquet rack with wheels 23 plates for 10 GN 1/1 oven and blast chiller freezer, 85mm pitch | PNC 922649 | <input type="checkbox"/> |
| • Kit universal skewer rack and 4 long skewers for Lenghtwise ovens | PNC 922324 | <input type="checkbox"/> | • Dehydration tray, GN 1/1, H=20mm | PNC 922651 | <input type="checkbox"/> |
| • Universal skewer rack | PNC 922326 | <input type="checkbox"/> | • Flat dehydration tray, GN 1/1 | PNC 922652 | <input type="checkbox"/> |
| • 4 long skewers | PNC 922327 | <input type="checkbox"/> | • Open base for 6 & 10 GN 1/1 oven, disassembled - NO accessory can be fitted with the exception of 922382 | PNC 922653 | <input type="checkbox"/> |
| • Multipurpose hook | PNC 922348 | <input type="checkbox"/> | • Bakery/pastry rack kit for 10 GN 1/1 oven with 8 racks 400x600mm and 80mm pitch | PNC 922656 | <input type="checkbox"/> |
| • 4 flanged feet for 6 & 10 GN , 2", 100-130mm | PNC 922351 | <input type="checkbox"/> | • Heat shield for stacked ovens 6 GN 1/1 on 10 GN 1/1 | PNC 922661 | <input type="checkbox"/> |
| • Grid for whole duck (8 per grid - 1,8kg each), GN 1/1 | PNC 922362 | <input type="checkbox"/> | • Heat shield for 10 GN 1/1 oven | PNC 922663 | <input type="checkbox"/> |
| • Thermal cover for 10 GN 1/1 oven and blast chiller freezer | PNC 922364 | <input type="checkbox"/> | • Kit to convert from natural gas to LPG | PNC 922670 | <input type="checkbox"/> |
| • Tray support for 6 & 10 GN 1/1 disassembled open base | PNC 922382 | <input type="checkbox"/> | • Kit to convert from LPG to natural gas | PNC 922671 | <input type="checkbox"/> |
| • Wall mounted detergent tank holder | PNC 922386 | <input type="checkbox"/> | • Flue condenser for gas oven | PNC 922678 | <input type="checkbox"/> |
| • USB single point probe | PNC 922390 | <input type="checkbox"/> | • Fixed tray rack for 10 GN 1/1 and 400x600mm grids | PNC 922685 | <input type="checkbox"/> |
| • IoT module for SkyLine ovens and blast chiller/freezers | PNC 922421 | <input type="checkbox"/> | • Kit to fix oven to the wall | PNC 922687 | <input type="checkbox"/> |
| • Tray rack with wheels 10 GN 1/1, 65mm pitch | PNC 922601 | <input type="checkbox"/> | • Tray support for 6 & 10 GN 1/1 oven base | PNC 922690 | <input type="checkbox"/> |
| | | | • 4 adjustable feet with black cover for 6 & 10 GN ovens, 100-115mm | PNC 922693 | <input type="checkbox"/> |

- Reinforced tray rack with wheels, lowest support dedicated to a grease collection tray for 10 GN 1/1 oven, 64mm pitch PNC 922694
 - Detergent tank holder for open base PNC 922699
 - Bakery/pastry runners 400x600mm for 6 & 10 GN 1/1 oven base PNC 922702
 - Wheels for stacked ovens PNC 922704
 - Spit for lamb or suckling pig (up to 12kg) for GN 1/1 ovens PNC 922709
 - Mesh grilling grid, GN 1/1 PNC 922713
 - Probe holder for liquids PNC 922714
 - Exhaust hood with fan for 6 & 10 GN 1/1 ovens PNC 922728
 - Exhaust hood with fan for stacking 6+6 or 6+10 GN 1/1 ovens PNC 922732
 - Exhaust hood without fan for 6&10 1/1GN ovens PNC 922733
 - Exhaust hood without fan for stacking 6+6 or 6+10 GN 1/1 ovens PNC 922737
 - Fixed tray rack, 8 GN 1/1, 85mm pitch PNC 922741
 - Fixed tray rack, 8 GN 2/1, 85mm pitch PNC 922742
 - 4 high adjustable feet for 6 & 10 GN ovens, 230-290mm PNC 922745
 - Tray for traditional static cooking, H=100mm PNC 922746
 - Double-face griddle, one side ribbed and one side smooth, 400x600mm PNC 922747
 - Trolley for grease collection kit PNC 922752
 - Water inlet pressure reducer PNC 922773
 - Extension for condensation tube, 37cm PNC 922776
 - Non-stick universal pan, GN 1/1, H=20mm PNC 925000
 - Non-stick universal pan, GN 1/1, H=40mm PNC 925001
 - Non-stick universal pan, GN 1/1, H=60mm PNC 925002
 - Double-face griddle, one side ribbed and one side smooth, GN 1/1 PNC 925003
 - Aluminum grill, GN 1/1 PNC 925004
 - Frying pan for 8 eggs, pancakes, hamburgers, GN 1/1 PNC 925005
 - Flat baking tray with 2 edges, GN 1/1 PNC 925006
 - Baking tray for 4 baguettes, GN 1/1 PNC 925007
 - Potato baker for 28 potatoes, GN 1/1 PNC 925008
 - Non-stick universal pan, GN 1/2, H=20mm PNC 925009
 - Non-stick universal pan, GN 1/2, H=40mm PNC 925010
 - Non-stick universal pan, GN 1/2, H=60mm PNC 925011
 - Compatibility kit for installation on previous base GN 1/1 PNC 930217
- C22 Cleaning Tab Disposable detergent tablets for SkyLine ovens Professional detergent for new generation ovens with automatic washing system. Suitable for all types of water. Packaging: 1 drum of 100 65g tablets. each PNC 0S2395

Recommended Detergents

- C25 Rinse & Descale tab 2in1 rinse aid and descaler in disposable tablets for Skyline ovens Professional 2in1 rinse aid and descaler in disposable tablets for new generation ovens with automatic washing system. Suitable for all types of water. Packaging: 1 drum of 50 30g tablets. each PNC 0S2394

Front

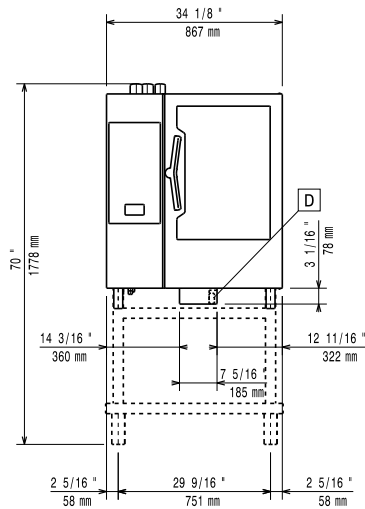

Side

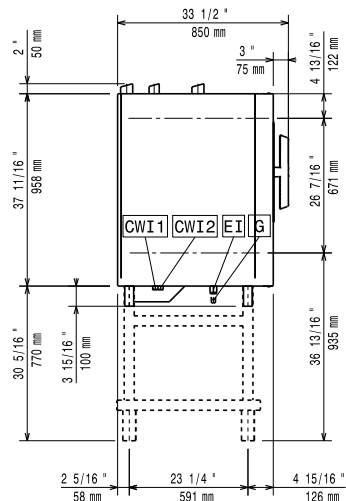

- CWI1 = Cold Water inlet 1 (cleaning) EI = Electrical inlet (power)
 CWI2 = Cold Water Inlet 2 (steam generator) G = Gas connection
 D = Drain
 DO = Overflow drain pipe

Top

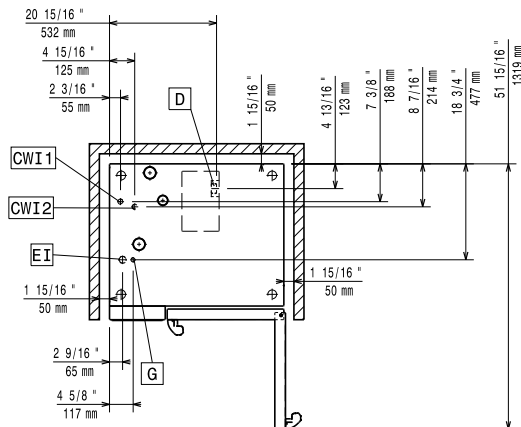

Electric

Supply voltage:

217962 (ECO101C2H0) 220-240 V/1 ph/50 Hz

Electrical power, default:

1.1 kW

Default power corresponds to factory test conditions. When supply voltage is declared as a range the test is performed at the average value. According to the country, the installed power may vary within the range.

Electrical power max.:

1.1 kW

Circuit breaker required

Gas

Gas Power:

21 kW

Standard gas delivery:

LPG, G31

ISO 7/1 gas connection diameter:

1/2" MNPT

Total thermal load:

71589 BTU (21 kW)

Water:

Water inlet connections "CWI1-CWI2":

3/4"

Pressure, bar min/max:

1-6 bar

Drain "D":

50mm

Max inlet water supply temperature:

30 °C

Hardness:

5 °fH / 2.8 °dH

Chlorides:

<10 ppm

Conductivity:

>50 µS/cm

Electrolux Professional recommends the use of treated water, based on testing of specific water conditions.

Please refer to user manual for detailed water quality information.

Installation:

Clearance:

Clearance: 5 cm rear and right hand sides.

Suggested clearance for service access:

50 cm left hand side.

Capacity:

Trays type:

10 - 1/1 Gastronorm

Max load capacity:

50 kg

Key Information:

Door hinges:

External dimensions, Width: 867 mm

External dimensions, Depth: 775 mm

External dimensions, Height: 1058 mm

Net weight: 136 kg

Shipping weight: 154 kg

Shipping volume: 1.06 m³

ISO Certificates

ISO Standards:

ISO 9001; ISO 14001; ISO 45001; ISO 50001